

# 74AVC16836A

20-bit registered driver with inverted register enable and  
Dynamic Controlled Outputs; 3-state

Rev. 6 — 24 September 2018

Product data sheet

## 1. General description

The 74AVC16836A is a 20-bit universal bus driver. Data flow is controlled by output enable ( $\overline{OE}$ ), latch enable ( $\overline{LE}$ ) and clock inputs (CP).

This product is designed to have an extremely fast propagation delay and a minimum amount of power consumption.

To ensure the high-impedance state during power up or power down,  $\overline{OE}$  should be tied to  $V_{CC}$  through a pullup resistor (Live Insertion).

A Dynamic Controlled Output (DCO) circuitry is implemented to support termination line drive during transient. See [Fig. 5](#) for typical curves.

## 2. Features and benefits

- Wide supply voltage range from 1.2 V to 3.6 V
- Complies with JEDEC standards:
  - JESD8-7 (1.2 V to 1.95 V)
  - JESD8-5 (1.8 V to 2.7 V)
  - JESD8-1A (2.7 V to 3.6 V)
- CMOS low power consumption
- Input/output tolerant up to 3.6 V
- Dynamic Controlled Output (DCO) circuit dynamically changes output impedance, resulting in noise reduction without speed degradation
- Low inductance multiple  $V_{CC}$  and GND pins to minimize noise and ground bounce
- Power off disables 74AVC16836A outputs, permitting Live Insertion
- Integrated input diodes to minimize input overshoot and undershoot

## 3. Ordering information

Table 1. Ordering information

Type number	Package			
	Temperature range	Name	Description	Version
74AVC16836ADGG	-40 °C to + 85 °C	TSSOP56	plastic thin shrink small outline package; 56 leads; body width 6.1 mm	SOT364-1

### 4. Functional diagram

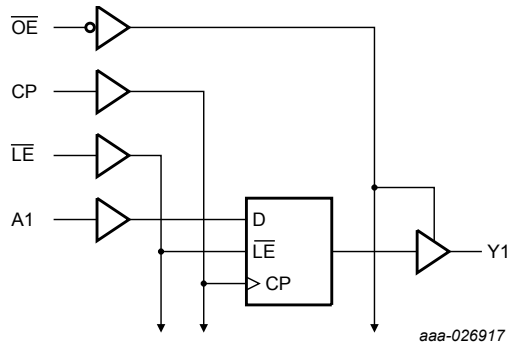

Fig. 1. Logic diagram

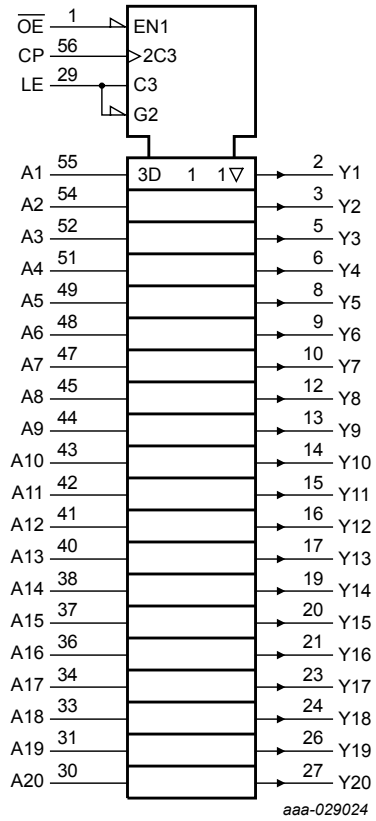

Fig. 2. Logic symbol (IEEE/IEC)

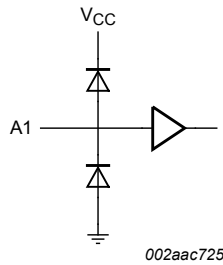

Fig. 3. Typical input (data or control)

## 5. Pinning information

### 5.1. Pinning

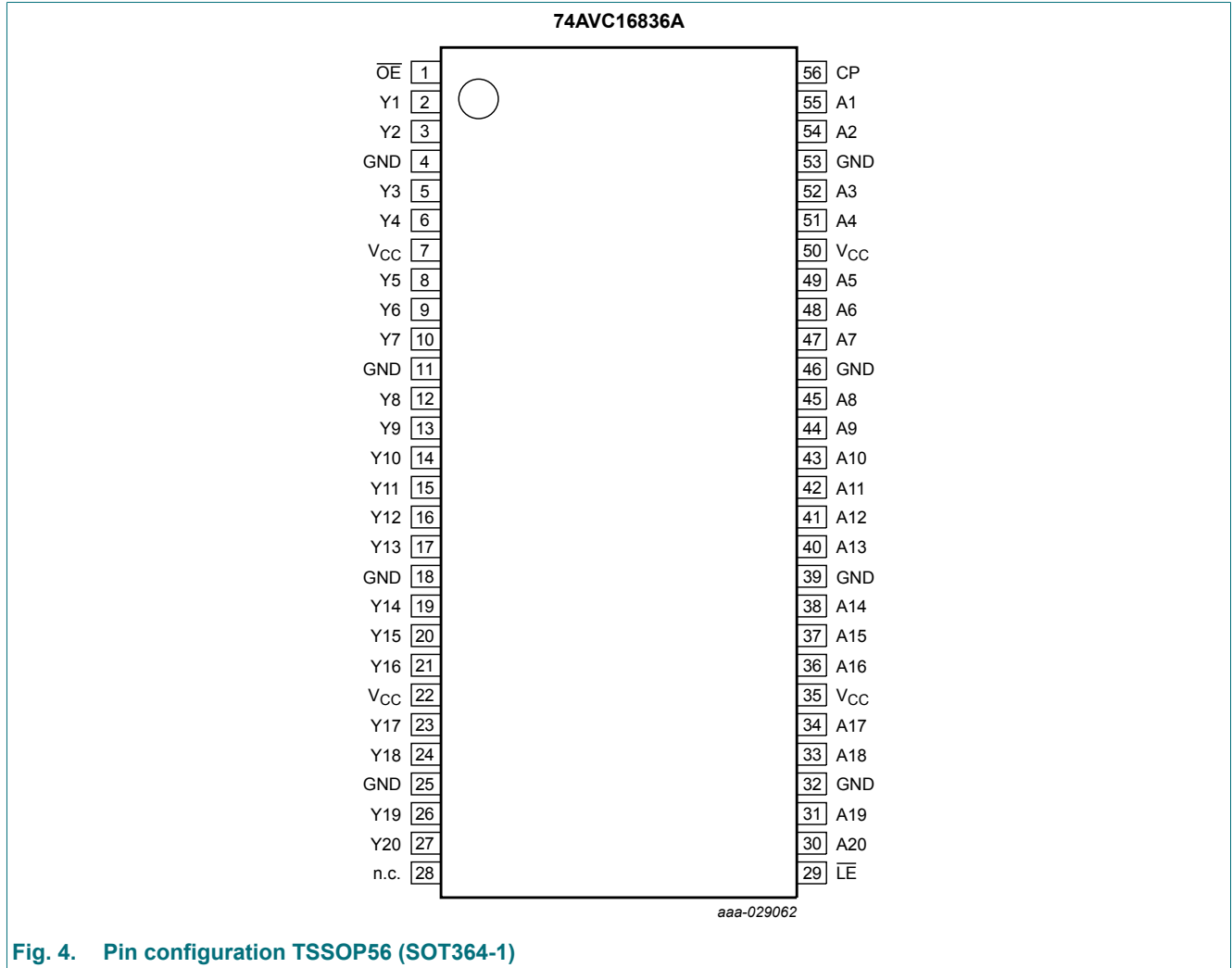

Fig. 4. Pin configuration TSSOP56 (SOT364-1)

## 5.2. Pin description

Table 2. Pin description

Symbol	Pin	Description
A1, A2, A3, A4, A5, A6, A7, A8, A9, A10, A11, A12, A13, A14, A15, A16, A17, A18, A19, A20	55, 54, 52, 51, 49, 48, 47, 45, 44, 43, 42, 41, 40, 38, 37, 36, 34, 33, 31, 30	data inputs
Y1, Y2, Y3, Y4, Y5, Y6, Y7, Y8, Y9, Y10, Y11, Y12, Y13, Y14, Y15, Y16, Y17, Y18, Y19, Y20	2, 3, 5, 6, 8, 9, 10, 12, 13, 14, 15, 16, 17, 19, 20, 21, 23, 24, 26, 27	data outputs
n.c.	28	not connected
$\overline{\text{LE}}$	29	latch enable input (active LOW)
$\overline{\text{OE}}$	1	output enable input (active LOW)
CP	56	clock input (LOW-to-HIGH, edge-triggered)
GND	4, 11, 18, 25, 32, 39, 46, 53	ground (0 V)
V <sub>CC</sub>	7, 22, 35, 50	supply voltage

## 6. Functional description

Table 3. Function selection

H = HIGH voltage level; L = LOW voltage level; X = Don't care; Z = high-impedance OFF-state;  $\uparrow$  = LOW to HIGH level transition.

Inputs				Outputs
OE	LE	CP	An	Yn
H	X	X	X	Z
L	L	X	L	L
L	L	X	H	H
L	H	$\uparrow$	L	L
L	H	$\uparrow$	H	H
L	H	H	X	Y <sub>0</sub> [1]
L	H	L	X	Y <sub>0</sub> [2]

[1] Output level before the indicated steady-state input conditions were established, provided that CP is high before  $\overline{\text{LE}}$  goes low.

[2] Output level before the indicated steady-state input conditions were established.

## 7. Limiting values

Table 4. Limiting values

In accordance with the Absolute Maximum Rating System (IEC 60134). Voltages are referenced to GND (ground = 0 V).

Symbol	Parameter	Conditions	Min	Max	Unit	
V <sub>CC</sub>	supply voltage		-0.5	+4.6	V	
I <sub>IK</sub>	input clamping current	V <sub>I</sub> < 0 V	-50	-	mA	
V <sub>I</sub>	input voltage	[1]	-0.5	+4.6	V	
I <sub>OK</sub>	output clamping current	V <sub>O</sub> > V <sub>CC</sub> or V <sub>O</sub> < 0 V	-	±50	mA	
V <sub>O</sub>	output voltage	output HIGH or LOW	[1]	-0.5	V <sub>CC</sub> + 0.5	V
		output 3-state	[1]	-0.5	+4.6	V
I <sub>O</sub>	output current	V <sub>O</sub> = 0 V to V <sub>CC</sub>	-	±50	mA	

## 20-bit registered driver with inverted register enable and Dynamic Controlled Outputs; 3-state

Symbol	Parameter	Conditions	Min	Max	Unit
$I_{CC}$	supply current		-	100	mA
$I_{GND}$	ground current		-100	-	mA
$T_{stg}$	storage temperature		-65	+150	°C
$P_{tot}$	total power dissipation	$T_{amb} = -40\text{ °C to }+85\text{ °C}$ [2]	-	600	mW

[1] The input and output voltage ratings may be exceeded if the input and output current ratings are observed.

[2] Above 55 °C the value of  $P_{tot}$  derates linearly with 8 mW/K.

## 8. Recommended operating conditions

Table 5. Recommended operating conditions

Symbol	Parameter	Conditions	Min	Typ	Max	Unit
$V_{CC}$	supply voltage	for low-voltage applications	1.2	-	3.6	V
		according to JEDEC Low Voltage Standards	1.65	-	1.95	V
			2.3	-	2.7	V
			3.0	-	3.6	V
$V_I$	input voltage	0	-	3.6	V	
$V_O$	output voltage	output HIGH or LOW	0	-	$V_{CC}$	V
		output 3-state	0	-	3.6	V
$T_{amb}$	ambient temperature	in free air	-40	-	+85	°C
$\Delta t/\Delta V$	input transition rise and fall rate	$V_{CC} = 1.65\text{ V to }2.3\text{ V}$	0	-	30	ns/V
		$V_{CC} = 2.3\text{ V to }3.0\text{ V}$	0	-	20	ns/V
		$V_{CC} = 3.0\text{ V to }3.6\text{ V}$	0	-	10	ns/V

## 9. Static characteristics

Table 6. Static characteristics

At recommended operating conditions;  $T_{amb} = -40\text{ °C to }+85\text{ °C}$ ; Voltages are referenced to GND (ground = 0 V).

Symbol	Parameter	Conditions	Min	Typ[1]	Max	Unit
$V_{IH}$	HIGH-level input voltage	$V_{CC} = 1.2\text{ V}$	$V_{CC}$	-	-	V
		$V_{CC} = 1.65\text{ V to }1.95\text{ V}$	$0.65 \times V_{CC}$	0.9	-	V
		$V_{CC} = 2.3\text{ V to }2.7\text{ V}$	1.7	1.2	-	V
		$V_{CC} = 3.0\text{ V to }3.6\text{ V}$	2.0	1.5	-	V
$V_{IL}$	LOW-level input voltage	$V_{CC} = 1.2\text{ V}$	-	-	GND	V
		$V_{CC} = 1.65\text{ V to }1.95\text{ V}$	-	0.9	$0.35 \times V_{CC}$	V
		$V_{CC} = 2.3\text{ V to }2.7\text{ V}$	-	1.2	0.7	V
		$V_{CC} = 3.0\text{ V to }3.6\text{ V}$	-	1.5	0.8	V

20-bit registered driver with inverted register enable and Dynamic Controlled Outputs; 3-state

Symbol	Parameter	Conditions	Min	Typ[1]	Max	Unit
V <sub>OH</sub>	HIGH-level output voltage	V <sub>I</sub> = V <sub>IH</sub> or V <sub>IL</sub>				
		I <sub>O</sub> = -100 μA; V <sub>CC</sub> = 1.65 V to 3.6 V	V <sub>CC</sub> - 0.20	V <sub>CC</sub>	-	V
		I <sub>O</sub> = -4 mA; V <sub>CC</sub> = 1.65 V	V <sub>CC</sub> - 0.45	V <sub>CC</sub> - 0.10	-	V
		I <sub>O</sub> = -8 mA; V <sub>CC</sub> = 2.3 V	V <sub>CC</sub> - 0.55	V <sub>CC</sub> - 0.28	-	V
		I <sub>O</sub> = -12 mA; V <sub>CC</sub> = 3.0 V	V <sub>CC</sub> - 0.70	V <sub>CC</sub> - 0.32	-	V
V <sub>OL</sub>	LOW-level output voltage	V <sub>I</sub> = V <sub>IH</sub> or V <sub>IL</sub>				
		I <sub>O</sub> = 100 μA; V <sub>CC</sub> = 1.65 V to 3.6 V	-	GND	0.20	V
		I <sub>O</sub> = 4 mA; V <sub>CC</sub> = 1.65 V	-	0.10	0.45	V
		I <sub>O</sub> = 8 mA; V <sub>CC</sub> = 2.3 V	-	0.26	0.55	V
		I <sub>O</sub> = 12 mA; V <sub>CC</sub> = 3.0 V	-	0.36	0.70	V
I <sub>I</sub>	input leakage current	V <sub>I</sub> = V <sub>CC</sub> or GND; V <sub>CC</sub> = 3.6 V	-	0.1	2.5	μA
I <sub>OFF</sub>	power-off leakage current	V <sub>I</sub> or V <sub>O</sub> = 3.6 V; V <sub>CC</sub> = 0 V	-	0.1	±10	μA
I <sub>OZ</sub>	OFF-state output current	V <sub>I</sub> = V <sub>IH</sub> or V <sub>IL</sub> ; V <sub>O</sub> = V <sub>CC</sub> or GND				
		V <sub>CC</sub> = 1.65 V to 2.7 V	-	0.1	5	μA
		V <sub>CC</sub> = 3.0 V to 3.6 V	-	0.1	10	μA
I <sub>CC</sub>	supply current	V <sub>I</sub> = V <sub>CC</sub> or GND; I <sub>O</sub> = 0 A				
		V <sub>CC</sub> = 1.65 V to 2.7 V	-	0.1	20	μA
		V <sub>CC</sub> = 3.0 V to 3.6 V	-	0.2	40	μA
C <sub>I</sub>	input capacitance		-	3.8	-	pF

[1] All typical values are measured at T<sub>amb</sub> = 25 °C.

### 9.1. Dynamic Controlled Output graphs

A Dynamic Controlled Output (DCO) circuit is designed in. During the transition, it initially lowers the output impedance to effectively drive the load and, subsequently, raises the impedance to reduce noise. Fig. 5 shows V<sub>OL</sub> vs. I<sub>OL</sub> and V<sub>OH</sub> vs. I<sub>OH</sub> curves to illustrate the output impedance and drive capability of the circuit. At the beginning of the signal transition, the DCO circuit provides a maximum dynamic drive that is equivalent to a high drive standard output device.

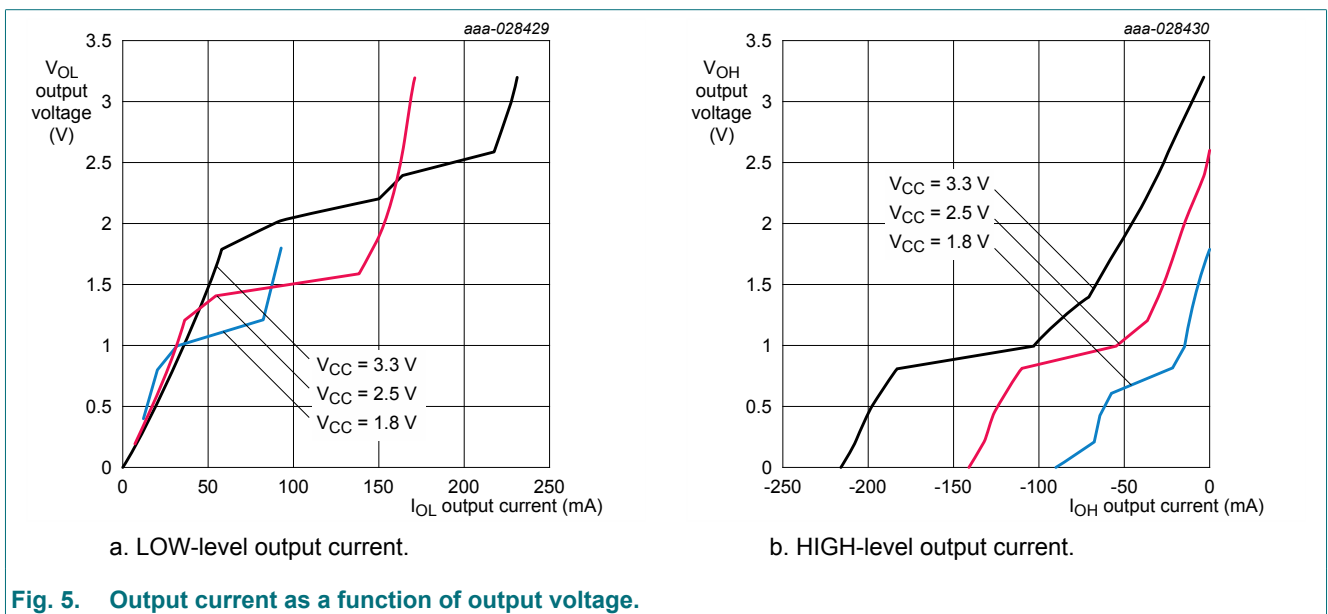

Fig. 5. Output current as a function of output voltage.

## 10. Dynamic characteristics

**Table 7. Dynamic characteristics**

Voltages are referenced to GND (ground = 0 V). For test circuit see [Fig. 12](#).

Symbol	Parameter	Conditions	Min	Typ [1]	Max	Unit
$t_{pd}$	propagation delay	An to Yn; see <a href="#">Fig. 6</a> [2]				
		$V_{CC} = 1.2\text{ V}$	-	4.7	-	ns
		$V_{CC} = 1.4\text{ V to }1.6\text{ V}$	2.0	-	5.3	ns
		$V_{CC} = 1.65\text{ V to }1.95\text{ V}$	1.0	2.4	4.4	ns
		$V_{CC} = 2.3\text{ V to }2.7\text{ V}$	0.8	1.7	3.2	ns
		$V_{CC} = 3.0\text{ V to }3.6\text{ V}$	0.7	1.5	2.7	ns
		$\overline{LE}$ to Yn; see <a href="#">Fig. 7</a> [2]				
		$V_{CC} = 1.2\text{ V}$	-	5.0	-	ns
		$V_{CC} = 1.4\text{ V to }1.6\text{ V}$	2.0	-	5.6	ns
		$V_{CC} = 1.65\text{ V to }1.95\text{ V}$	1.5	2.7	5.0	ns
		$V_{CC} = 2.3\text{ V to }2.7\text{ V}$	1.0	2.1	3.5	ns
		$V_{CC} = 3.0\text{ V to }3.6\text{ V}$	0.7	1.7	3.4	ns
		CP to Yn; see <a href="#">Fig. 9</a> [2]				
		$V_{CC} = 1.2\text{ V}$	-	5.7	-	ns
		$V_{CC} = 1.4\text{ V to }1.6\text{ V}$	2.0	-	4.7	ns
$V_{CC} = 1.65\text{ V to }1.95\text{ V}$	1.2	2.3	4.1	ns		
$V_{CC} = 2.3\text{ V to }2.7\text{ V}$	0.8	1.7	3.2	ns		
$V_{CC} = 3.0\text{ V to }3.6\text{ V}$	0.7	1.6	3.0	ns		
$t_{en}$	enable time	$\overline{OE}$ to Yn; see <a href="#">Fig. 11</a> [2]				
		$V_{CC} = 1.2\text{ V}$	-	6.0	-	ns
		$V_{CC} = 1.4\text{ V to }1.6\text{ V}$	2.5	-	6.8	ns
		$V_{CC} = 1.65\text{ V to }1.95\text{ V}$	1.5	3.0	5.4	ns
		$V_{CC} = 2.3\text{ V to }2.7\text{ V}$	1.0	2.4	4.0	ns
$V_{CC} = 3.0\text{ V to }3.6\text{ V}$	1.0	1.9	3.6	ns		
$t_{dis}$	disable time	$\overline{OE}$ to Yn; see <a href="#">Fig. 11</a> [2]				
		$V_{CC} = 1.2\text{ V}$	-	6.6	-	ns
		$V_{CC} = 1.4\text{ V to }1.6\text{ V}$	2.5	-	7.6	ns
		$V_{CC} = 1.65\text{ V to }1.95\text{ V}$	1.5	3.7	7.5	ns
		$V_{CC} = 2.3\text{ V to }2.7\text{ V}$	1.0	2.1	4.7	ns
$V_{CC} = 3.0\text{ V to }3.6\text{ V}$	1.0	2.5	4.8	ns		
$t_w$	pulse width	CP HIGH or LOW; see <a href="#">Fig. 9</a> .				
		$V_{CC} = 1.65\text{ V to }1.95\text{ V}$	2.0	-	-	ns
		$V_{CC} = 2.3\text{ V to }2.7\text{ V}$	1.2	-	-	ns
		$V_{CC} = 3.0\text{ V to }3.6\text{ V}$	1.0	-	-	ns
		$\overline{LE}$ HIGH; see <a href="#">Fig. 7</a> .				
		$V_{CC} = 1.65\text{ V to }1.95\text{ V}$	2.0	-	-	ns
		$V_{CC} = 2.3\text{ V to }2.7\text{ V}$	1.2	-	-	ns
$V_{CC} = 3.0\text{ V to }3.6\text{ V}$	1.0	-	-	ns		

## 20-bit registered driver with inverted register enable and Dynamic Controlled Outputs; 3-state

Symbol	Parameter	Conditions	Min	Typ [1]	Max	Unit
t <sub>su</sub>	set-up time	An to CP; see Fig. 10				
		V <sub>CC</sub> = 1.2 V	-	0.0	-	ns
		V <sub>CC</sub> = 1.4 V to 1.6 V	0.3	-	-	ns
		V <sub>CC</sub> = 1.65 V to 1.95 V	0.2	0.0	-	ns
		V <sub>CC</sub> = 2.3 V to 2.7 V	0.3	0.0	-	ns
		V <sub>CC</sub> = 3.0 V to 3.6 V	0.2	0.0	-	ns
		An to $\overline{\text{LE}}$ ; see Fig. 8				
		V <sub>CC</sub> = 1.2 V	-	1.2	-	ns
		V <sub>CC</sub> = 1.4 V to 1.6 V	1.3	-	-	ns
		V <sub>CC</sub> = 1.65 V to 1.95 V	0.9	0.4	-	ns
		V <sub>CC</sub> = 2.3 V to 2.7 V	0.6	0.2	-	ns
V <sub>CC</sub> = 3.0 V to 3.6 V	0.3	0.0	-	ns		
t <sub>h</sub>	hold time	An to CP; see Fig. 10				
		V <sub>CC</sub> = 1.2 V	-	0.1	-	ns
		V <sub>CC</sub> = 1.4 V to 1.6 V	0.6	-	-	ns
		V <sub>CC</sub> = 1.65 V to 1.95 V	0.6	0.2	-	ns
		V <sub>CC</sub> = 2.3 V to 2.7 V	0.6	0.2	-	ns
		V <sub>CC</sub> = 3.0 V to 3.6 V	1.2	0.5	-	ns
		An to $\overline{\text{LE}}$ ; see Fig. 8				
		V <sub>CC</sub> = 1.2 V	-	-0.7	-	ns
		V <sub>CC</sub> = 1.4 V to 1.6 V	0.2	-	-	ns
		V <sub>CC</sub> = 1.65 V to 1.95 V	0.4	0.0	-	ns
		V <sub>CC</sub> = 2.3 V to 2.7 V	0.5	0.1	-	ns
V <sub>CC</sub> = 3.0 V to 3.6 V	1.0	0.5	-	ns		
f <sub>max</sub>	maximum frequency	CP; see Fig. 9				
		V <sub>CC</sub> = 1.65 V to 1.95 V	250	-	-	MHz
		V <sub>CC</sub> = 2.3 V to 2.7 V	400	-	-	MHz
		V <sub>CC</sub> = 3.0 V to 3.6 V	500	-	-	MHz
C <sub>PD</sub>	power dissipation capacitance	per buffer; V <sub>I</sub> = GND to V <sub>CC</sub> [3]				
		outputs enabled	-	25	-	pF
		outputs disabled	-	6	-	pF

[1] Typical values are measured at T<sub>amb</sub> = 25 °C and V<sub>CC</sub> = 1.5 V, 1.8 V, 2.5 V and 3.3 V respectively.

[2] t<sub>pd</sub> is the same as t<sub>PLH</sub> and t<sub>PHL</sub>.

t<sub>en</sub> is the same as t<sub>PZL</sub> and t<sub>PZH</sub>.

t<sub>dis</sub> is the same as t<sub>PLZ</sub> and t<sub>PHZ</sub>.

[3] C<sub>PD</sub> is used to determine the dynamic power dissipation (P<sub>D</sub> in μW).

$P_D = C_{PD} \times V_{CC}^2 \times f_i \times N + \Sigma(C_L \times V_{CC}^2 \times f_o)$  where:

f<sub>i</sub> = input frequency in MHz;

f<sub>o</sub> = output frequency in MHz

C<sub>L</sub> = output load capacitance in pF

V<sub>CC</sub> = supply voltage in Volts

N = number of inputs switching

$\Sigma(C_L \times V_{CC}^2 \times f_o)$  = sum of the outputs.

10.1. Waveforms and test circuit

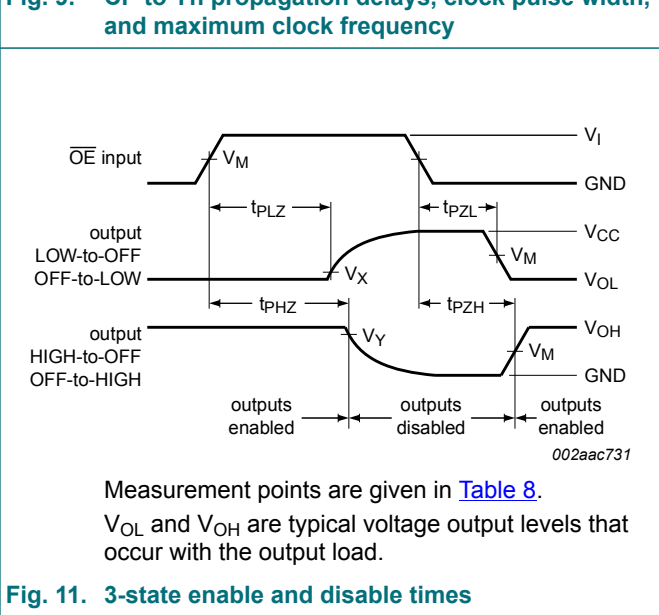
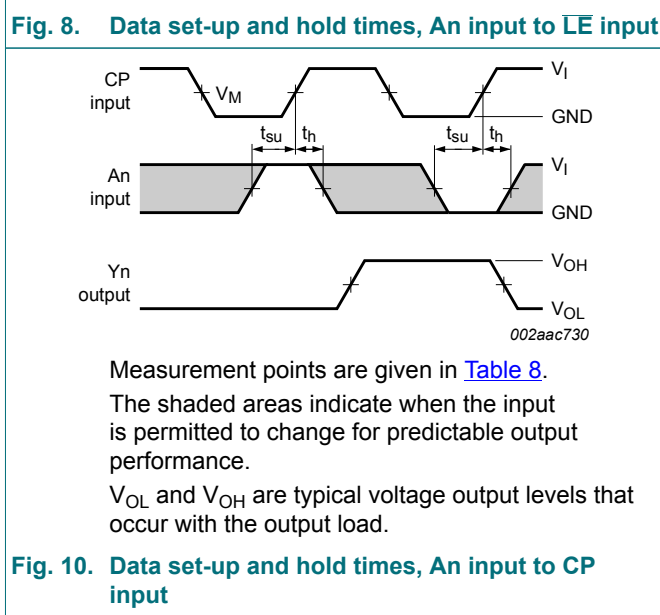
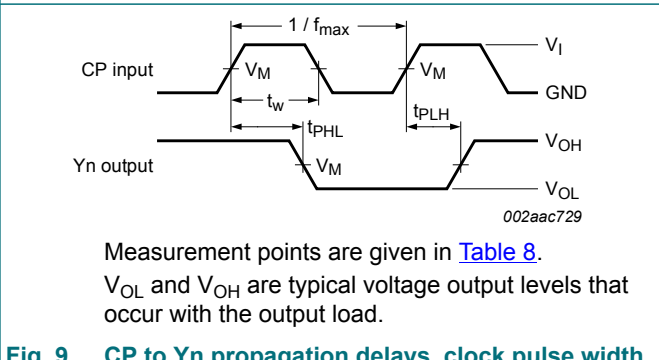
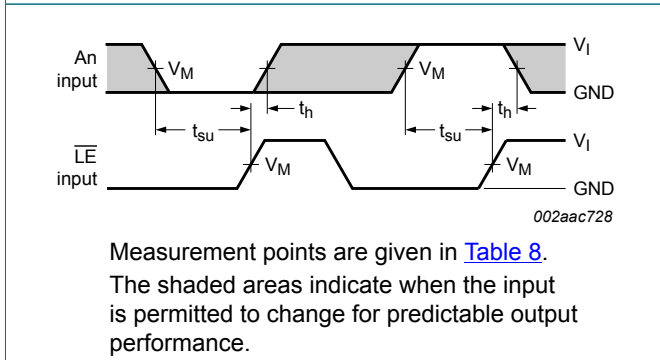
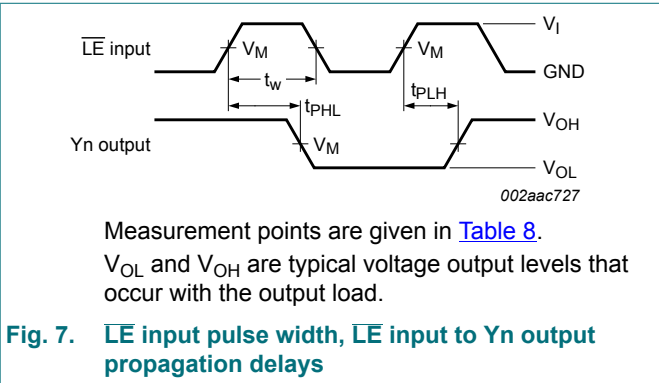
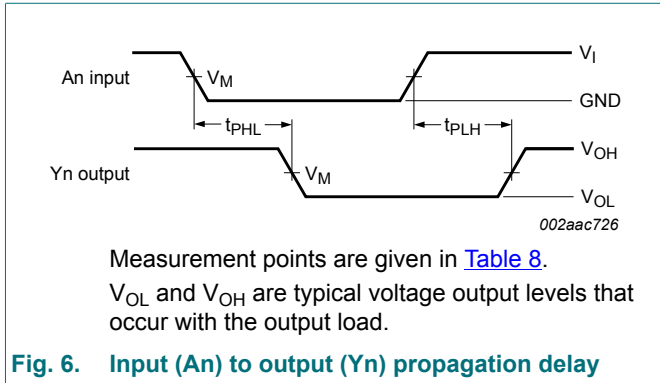
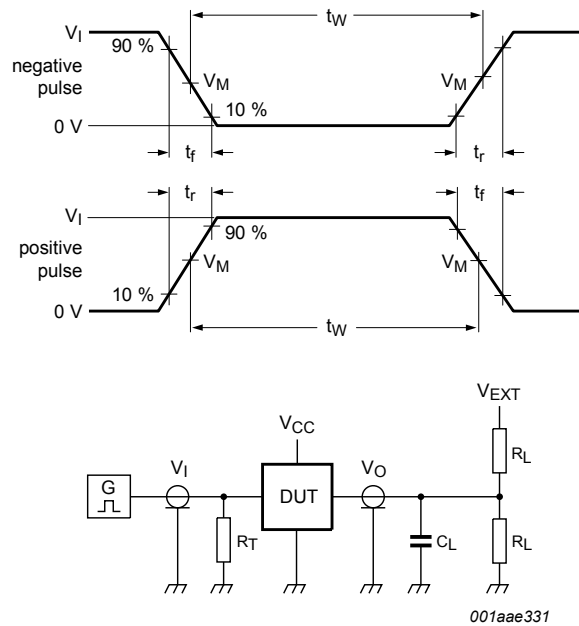

Table 8. Measurement points

Supply voltage	Input		Output		
$V_{CC}$	$V_I$	$V_M$	$V_M$	$V_X$	$V_Y$
$\leq 2.3\text{ V}$	$V_{CC}$	$0.5 \times V_{CC}$	$0.5 \times V_{CC}$	$V_{OL} + 0.15\text{ V}$	$V_{OH} - 0.15\text{ V}$
2.3 V to 2.7 V	$V_{CC}$	$0.5 \times V_{CC}$	$0.5 \times V_{CC}$	$V_{OL} + 0.15\text{ V}$	$V_{OH} - 0.15\text{ V}$
3.0 V to 3.6 V	$V_{CC}$	$0.5 \times V_{CC}$	$0.5 \times V_{CC}$	$V_{OL} + 0.3\text{ V}$	$V_{OH} - 0.3\text{ V}$

20-bit registered driver with inverted register enable and Dynamic Controlled Outputs; 3-state



Test data is given in [Table 9](#).

Definitions for test circuit:

$R_L$  = Load resistance.

$C_L$  = Load capacitance including jig and probe capacitance.

$R_T$  = Termination resistance should be equal to output impedance  $Z_o$  of the pulse generator.

$V_{EXT}$  = External voltage for measuring switching times.

**Fig. 12. Test circuit for measuring switching times**

**Table 9. Test data**

Supply voltage	Input		Load		$V_{EXT}$		
$V_{CC}$	$V_I$	$t_r, t_f$	$C_L$	$R_L$	$t_{PLH}, t_{PHL}$	$t_{PLZ}, t_{PZL}$	$t_{PHZ}, t_{PZH}$
$\leq 2.3$ V	$V_{CC}$	$\leq 2.0$ ns	30 pF	1000 $\Omega$	open	$2 \times V_{CC}$	GND
2.3 V to 2.7 V	$V_{CC}$	$\leq 2.0$ ns	30 pF	500 $\Omega$	open	$2 \times V_{CC}$	GND
3.0 V to 3.6 V	$V_{CC}$	$\leq 2.0$ ns	30 pF	500 $\Omega$	open	$2 \times V_{CC}$	GND

### 11. Package outline

TSSOP56: plastic thin shrink small outline package; 56 leads; body width 6.1 mm

SOT364-1

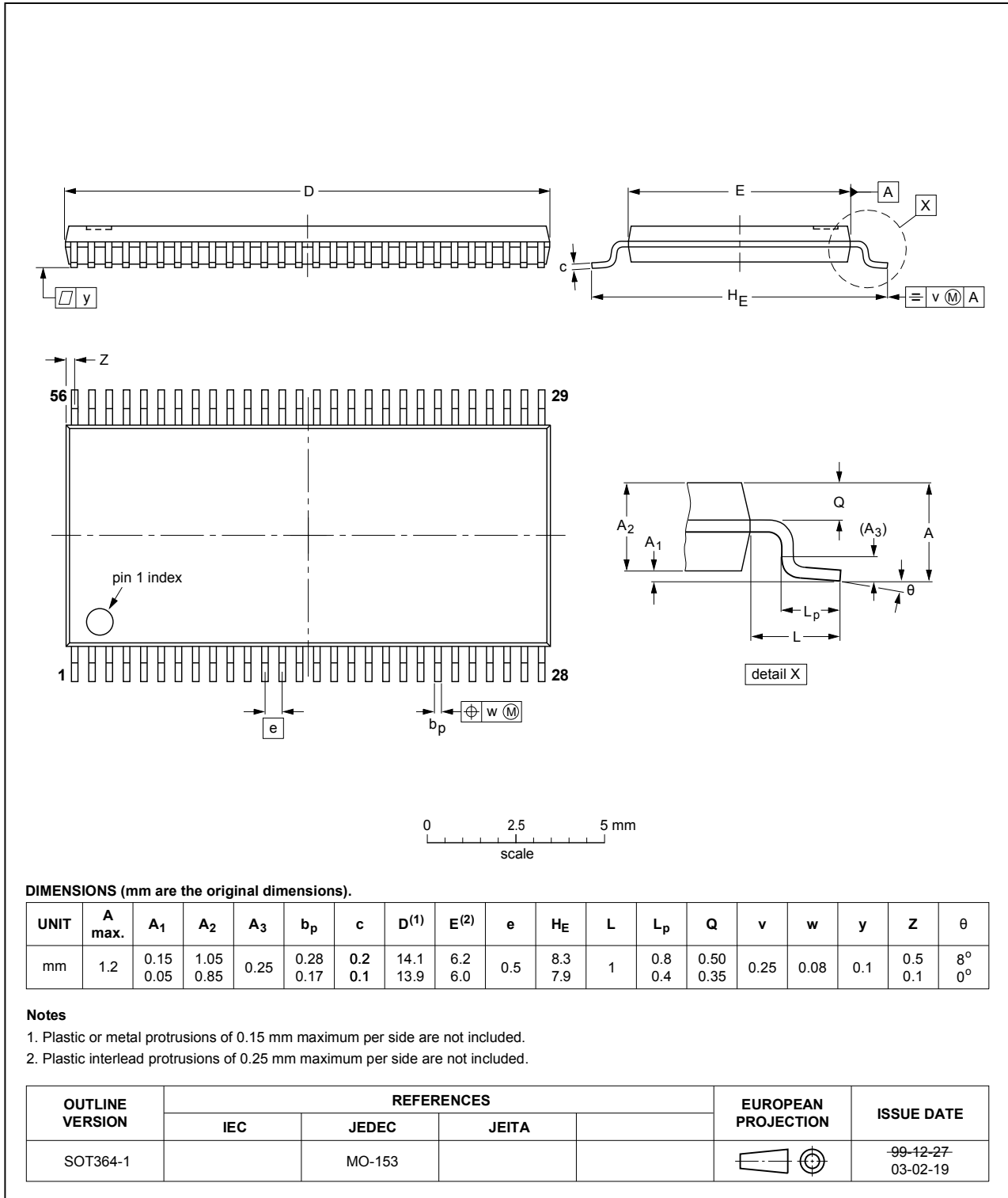

Fig. 13. Package outline SOT364-1 (TSSOP56)

## 12. Abbreviations

Table 10. Abbreviations

Acronym	Description
CMOS	Complementary Metal-Oxide Semiconductor
DCO	Dynamic Controlled Output
DUT	Device Under Test

## 13. Revision history

Table 11. Revision history

Document ID	Release date	Data sheet status	Change notice	Supersedes
74AVC16836A v.6	20180924	Product data sheet	-	74AVC16836A v.5
Modifications:	<ul style="list-style-type: none"> <li>The format of this data sheet has been redesigned to comply with the identity guidelines of Nexperia.</li> <li>Legal texts have been adapted to the new company name where appropriate.</li> <li>Type number 74AVC16836ADGV (SOT481-2) removed.</li> </ul>			
74AVC16836A v.5	20020802	Product data sheet	-	74AVC16836A v.4
74AVC16836A v.4	20000803	Product specification	-	74AVC16836A v.3
74AVC16836A v.3	20000502	Preliminary specification	-	74AVC16836 v.2
74AVC16836 v.2	19990723	Preliminary specification	-	74AVC_AVCH16836 v.1
74AVC_AVCH16836 v.1	19981207	Objective specification	-	-

## 14. Legal information

### Data sheet status

Document status [1][2]	Product status [3]	Definition
Objective [short] data sheet	Development	This document contains data from the objective specification for product development.
Preliminary [short] data sheet	Qualification	This document contains data from the preliminary specification.
Product [short] data sheet	Production	This document contains the product specification.

- [1] Please consult the most recently issued document before initiating or completing a design.
- [2] The term 'short data sheet' is explained in section "Definitions".
- [3] The product status of device(s) described in this document may have changed since this document was published and may differ in case of multiple devices. The latest product status information is available on the internet at <https://www.nexperia.com>.

### Definitions

**Draft** — The document is a draft version only. The content is still under internal review and subject to formal approval, which may result in modifications or additions. Nexperia does not give any representations or warranties as to the accuracy or completeness of information included herein and shall have no liability for the consequences of use of such information.

**Short data sheet** — A short data sheet is an extract from a full data sheet with the same product type number(s) and title. A short data sheet is intended for quick reference only and should not be relied upon to contain detailed and full information. For detailed and full information see the relevant full data sheet, which is available on request via the local Nexperia sales office. In case of any inconsistency or conflict with the short data sheet, the full data sheet shall prevail.

**Product specification** — The information and data provided in a Product data sheet shall define the specification of the product as agreed between Nexperia and its customer, unless Nexperia and customer have explicitly agreed otherwise in writing. In no event however, shall an agreement be valid in which the Nexperia product is deemed to offer functions and qualities beyond those described in the Product data sheet.

### Disclaimers

**Limited warranty and liability** — Information in this document is believed to be accurate and reliable. However, Nexperia does not give any representations or warranties, expressed or implied, as to the accuracy or completeness of such information and shall have no liability for the consequences of use of such information. Nexperia takes no responsibility for the content in this document if provided by an information source outside of Nexperia.

In no event shall Nexperia be liable for any indirect, incidental, punitive, special or consequential damages (including - without limitation - lost profits, lost savings, business interruption, costs related to the removal or replacement of any products or rework charges) whether or not such damages are based on tort (including negligence), warranty, breach of contract or any other legal theory.

Notwithstanding any damages that customer might incur for any reason whatsoever, Nexperia's aggregate and cumulative liability towards customer for the products described herein shall be limited in accordance with the Terms and conditions of commercial sale of Nexperia.

**Right to make changes** — Nexperia reserves the right to make changes to information published in this document, including without limitation specifications and product descriptions, at any time and without notice. This document supersedes and replaces all information supplied prior to the publication hereof.

**Suitability for use** — Nexperia products are not designed, authorized or warranted to be suitable for use in life support, life-critical or safety-critical systems or equipment, nor in applications where failure or malfunction of an Nexperia product can reasonably be expected to result in personal

injury, death or severe property or environmental damage. Nexperia and its suppliers accept no liability for inclusion and/or use of Nexperia products in such equipment or applications and therefore such inclusion and/or use is at the customer's own risk.

**Quick reference data** — The Quick reference data is an extract of the product data given in the Limiting values and Characteristics sections of this document, and as such is not complete, exhaustive or legally binding.

**Applications** — Applications that are described herein for any of these products are for illustrative purposes only. Nexperia makes no representation or warranty that such applications will be suitable for the specified use without further testing or modification.

Customers are responsible for the design and operation of their applications and products using Nexperia products, and Nexperia accepts no liability for any assistance with applications or customer product design. It is customer's sole responsibility to determine whether the Nexperia product is suitable and fit for the customer's applications and products planned, as well as for the planned application and use of customer's third party customer(s). Customers should provide appropriate design and operating safeguards to minimize the risks associated with their applications and products.

Nexperia does not accept any liability related to any default, damage, costs or problem which is based on any weakness or default in the customer's applications or products, or the application or use by customer's third party customer(s). Customer is responsible for doing all necessary testing for the customer's applications and products using Nexperia products in order to avoid a default of the applications and the products or of the application or use by customer's third party customer(s). Nexperia does not accept any liability in this respect.

**Limiting values** — Stress above one or more limiting values (as defined in the Absolute Maximum Ratings System of IEC 60134) will cause permanent damage to the device. Limiting values are stress ratings only and (proper) operation of the device at these or any other conditions above those given in the Recommended operating conditions section (if present) or the Characteristics sections of this document is not warranted. Constant or repeated exposure to limiting values will permanently and irreversibly affect the quality and reliability of the device.

**Terms and conditions of commercial sale** — Nexperia products are sold subject to the general terms and conditions of commercial sale, as published at <http://www.nexperia.com/profile/terms>, unless otherwise agreed in a valid written individual agreement. In case an individual agreement is concluded only the terms and conditions of the respective agreement shall apply. Nexperia hereby expressly objects to applying the customer's general terms and conditions with regard to the purchase of Nexperia products by customer.

**No offer to sell or license** — Nothing in this document may be interpreted or construed as an offer to sell products that is open for acceptance or the grant, conveyance or implication of any license under any copyrights, patents or other industrial or intellectual property rights.

**Export control** — This document as well as the item(s) described herein may be subject to export control regulations. Export might require a prior authorization from competent authorities.

**Non-automotive qualified products** — Unless this data sheet expressly states that this specific Nexperia product is automotive qualified, the product is not suitable for automotive use. It is neither qualified nor tested in accordance with automotive testing or application requirements. Nexperia accepts no liability for inclusion and/or use of non-automotive qualified products in automotive equipment or applications.

In the event that customer uses the product for design-in and use in automotive applications to automotive specifications and standards, customer (a) shall use the product without Nexperia's warranty of the product for such automotive applications, use and specifications, and (b) whenever customer uses the product for automotive applications beyond Nexperia's specifications such use shall be solely at customer's own risk, and (c) customer fully indemnifies Nexperia for any liability, damages or failed product claims resulting from customer design and use of the product for automotive applications beyond Nexperia's standard warranty and Nexperia's product specifications.

**Translations** — A non-English (translated) version of a document is for reference only. The English version shall prevail in case of any discrepancy between the translated and English versions.

### Trademarks

Notice: All referenced brands, product names, service names and trademarks are the property of their respective owners.

## Contents

---

<b>1. General description</b> .....	<b>1</b>
<b>2. Features and benefits</b> .....	<b>1</b>
<b>3. Ordering information</b> .....	<b>1</b>
<b>4. Functional diagram</b> .....	<b>2</b>
<b>5. Pinning information</b> .....	<b>3</b>
5.1. Pinning.....	3
5.2. Pin description.....	4
<b>6. Functional description</b> .....	<b>4</b>
<b>7. Limiting values</b> .....	<b>4</b>
<b>8. Recommended operating conditions</b> .....	<b>5</b>
<b>9. Static characteristics</b> .....	<b>5</b>
9.1. Dynamic Controlled Output graphs.....	6
<b>10. Dynamic characteristics</b> .....	<b>7</b>
10.1. Waveforms and test circuit.....	9
<b>11. Package outline</b> .....	<b>11</b>
<b>12. Abbreviations</b> .....	<b>12</b>
<b>13. Revision history</b> .....	<b>12</b>
<b>14. Legal information</b> .....	<b>13</b>

---

© Nexperia B.V. 2018. All rights reserved

For more information, please visit: <http://www.nexperia.com>

For sales office addresses, please send an email to: [salesaddresses@nexperia.com](mailto:salesaddresses@nexperia.com)

Date of release: 24 September 2018

---